

SRT

TRUNKING SYSTEM

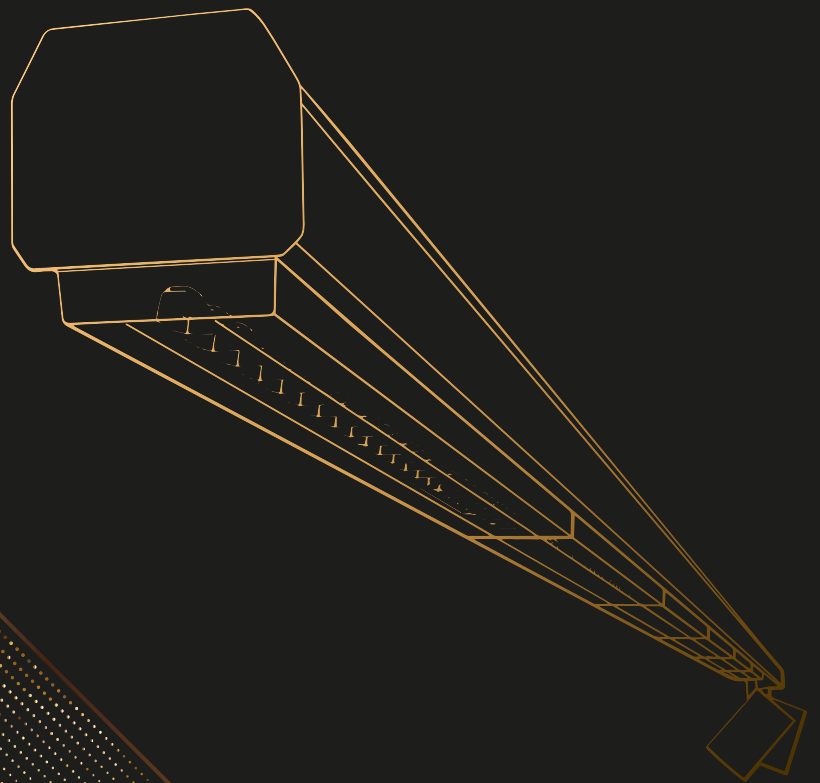

REGIOLUX

SRT

TRUNKING SYSTEM

Whatever you are planning:
the SRT trunking system
is what you need!

SRT – tailor-made thanks to BTO concept

Our "Build-to-Order" concept lets us
configure bespoke product variants for
your individual needs. So you get a
tailor-made lighting system.

CONTENTS

Contents.....	3	Guide To Gear Tray Types	52
SRT-Highlights	5	Gear Trays – Function Modules	54
Evolution – The Technical DNA.....	7	Emergency Light Module <i>safe</i>	56
Focus On Application Areas	9	Spotlight <i>spotty-maxi</i>	58
Logistics	9	Area Luminaire <i>zatta</i>	60
Industry.....	11	Track <i>SRGD</i>	61
Retail.....	13	Light Management <i>netlife</i>	62
Education.....	15	Quality Features	68
Office	17	Trunking Configuration.....	70
Freedom For Light Planning.....	18	Planning Examples.....	73
Structure Of The System.....	20	Logistics Project.....	73
Focus: Dual Concept.....	22	Industry Project	75
Form Factor SRT Trunking	24	Retail Project	77
Mounting Rail	26	Education Project	79
Wiring + System Lengths.....	26	Office Project.....	81
Infeed – Connection – Outfeed.....	28	Packaging Concept	82
Accessories	30	Customer Service.....	83
Gear Tray – Main Features.....	32	InfoCentre.....	84
Gear Tray – Lighting Technologies	34	Contact.....	86
Central.Line.Optic	36	Regiolux Inhouse	86
Diffusers	40	Deutschland.....	87
Individual.Lens.Optic	44	International.....	88
Overview Of Lighting Technology.....	48	Photo Index	90
Light Quality And Light Colour	50		



■ ■ ■
Made in Germany

SRT HIGHLIGHTS



- + The flexible trunking system for bespoke solutions
- + 1 mounting rail for any type of project: logistics, industry, retail, school, office
- + 14 light distributions combined with numerous luminous flux packages and a peak efficiency of 195 lm/W
- + 100% variable positioning in IP20 and IP54
- + Outstanding lighting technology and design: Central.Line.Optic – the perfect light line
- + Cost-optimised systems with long module /2250 and economic rail
- + Function module /750 opens up system solutions for 5 further tasks
- + Extremely fast installation thanks to push system and plug & play modules
- + High-performance versions (HP) with a service life of up to 100,000 h
- + Suitable for ambient temperatures from -20 to +50 °C





EVOLUTION

THE TECHNICAL DNA

The development of SRT trunking systems has an evolutionary character. Evolution results from diversity and can be understood as the successful adaptation to changes in circumstances. The basic technical DNA from decades of successful improvements to our modular trunking systems is not lost and is being developed even further. Just like in biology, tried and trusted methods last.

Our DNA reacts and adapts to the latest tasks. New technological possibilities arise and solutions are found to new challenges. This is where the SRT system comes into its own with modular equipment. LED, power supply and control are breaking new ground. Everything is open to individual requirements in terms of flexibility for the most varied of applications. Even the form factor has been changed almost imperceptibly.

We have already come a long way and are continuing to make progress in the technical evolution of our trunking systems.

We invite you to join us!





LOGISTICS

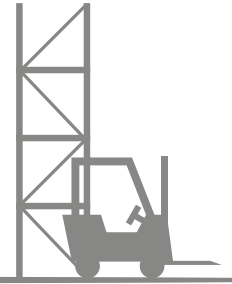

- + The latest generation of LED: powerful modules up to 22,000 lm, peak values of 44,000 lm over a section of 4,5 m
- + New application-optimised lens technology: Central.Line.Optic – the economical light line
- + Costs firmly in sight: fewer light points and fast installation with long module /2250
- + Perfectly illuminated racks and ceiling brightening thanks to prismatic diffuser technology
- + Convenient bulk or individual packaging saves time, effort and costs, also for the environment.
- + netlife controls – for smart concepts in light management





INDUSTRY

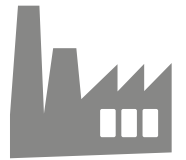

- + 14 different optics with lumen packages from 4,000–22,000 lm
- + Variable position gear trays – even for IP54.
- + Central.Line.Optic with a peak efficiency of 195 lm/W
- + Saving right from the very beginning: CLO – constant luminous flux over the entire service life
- + Adaptations to varying room uses can be easily implemented using multi-lumen drivers.
- + SRT brings HCL lighting concepts to production areas
- + More safety in the building with the *safe* function module
- + Suitable for ambient temperatures from –20 to +50 °C





RETAIL



- + Linear, planar and accent lighting differentiate your product presentation.
- + Different housing colours and 3 module lengths to match the store design.
- + 100% variable positioning of the light modules
- + The right accentuated light for every class of goods: colour rendering index CRI > 90 for spot lighting
- + Function modules bring flexibility for smart light management and more.
- + Advanced Services help solve your indoor navigation, networking or IoT project.



EDUCATION

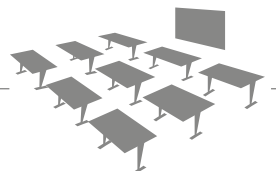

- + Specific optics for all learning and study zones
- + Good glare control for visual comfort supports the ability to focus.
- + Light keeps concentration high. Tunable white technology ensures biologically effective light.
- + Problem-free upgrades via Bluetooth and app.
- + Build-To-Order (BTO) concept makes non-standard solutions possible.
- + From conception to commissioning: the know-how decides the success of a multi-faceted projects.





OFFICE



- + Light lines for office concepts in industrial design
- + Optimum glare control ($UGR \leq 19$) for computer workstations (VDU) in accordance with DIN EN 12464-1
- + A wide variety of lighting technologies for matching lighting concepts in offices and ancillary rooms
- + Lighting quality for concentration and creativity
- + netlife control for light appropriate to needs
- + Convenience through connection to building management systems and cloud solutions

PLANNING FREEDOM

Extend your options through individual project solutions with Build-to-Order (BTO).

1 mounting rail



3 housing colours



vw traffic white
RAL 9016



sg silver grey/white aluminium
RAL 9006



sw black
RAL 9005

3 protection ratings



2 through-wirings



2 types of installation

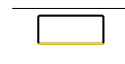
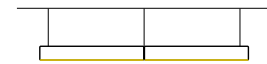

3 gear tray module lengths

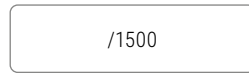

Positioning of the gear trays



fixed



variable

3 types of optics



Central.Line.Optic



Individual.Lens.Optic



Diffuser

14 light distributions



...

∞ lumen packages

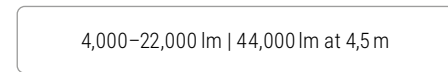

4 light colours



warm white
3000K



neutral white
4000K



Daylight white
6500K



HCL

Colour rendering



6 types of switching



5 function modules



netlife



safe



spotty-m



zatta



Track

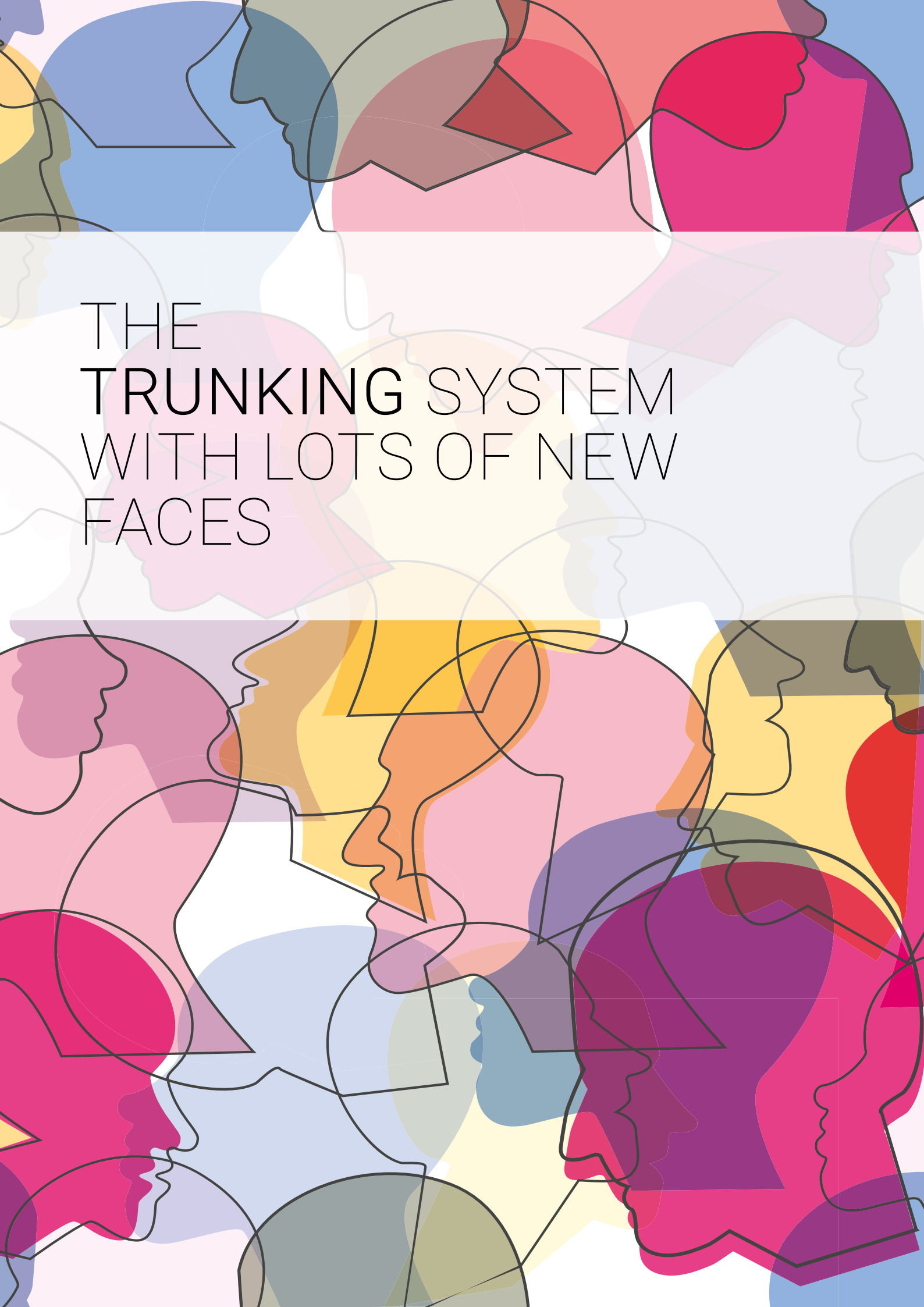

THE
TRUNKING SYSTEM
WITH LOTS OF NEW
FACES

SYSTEM

SETUP

ACCESSORIES

- Fixings
- Infeeds/outfeeds
- End faces
- Mounting rail connectors/nodes

MOUNTING RAIL

ALL PROTECTION RATINGS WITH 1 MOUNTING RAIL

IP20 IP40 IP54

7-pin 11-pin

GEAR TRAY

MODULE /1500



Central.Line.Optic



Individual.Lens.Optic



Diffusers

MODULE /2250



Central.Line.Optic



Individual.Lens.Optic

POSITIONING OF THE GEAR TRAYS

fixed or variable in IP54 and IP20



COLOURS

vw traffic white
RAL 9016

sg silver grey/white aluminium
RAL 9006

sw black
RAL 9005

FUNCTION MODULE/750

- Spotlight *spotty-maxi*
- Area luminaire *zatta*
- Light management *netlife*
- Emergency luminaire *safe*
- Track *SRGD*

Build-to-Order

Our concept for your customised project solutions: Build-to-Order (BTO)

FOCUS

DUAL CONCEPT



Our way of solving challenges

+ Future-proof mounting rail system:

- LED gear trays are exchangeable and compatible for long-term use.
- The trunking can be easily adapted to new challenges.
- Mounting rail and electrical installation remain in place during refurbishment work.

+ More flexibility for additional functions:

- Single-conductor wiring: various cable cross-sections to choose from
- Increased number of current taps

+ Pre-defined current taps make the system design a start-to-finish victory during assembly.

1

Quick-fit mounting rail

2

Exchangeable LED gear trays



**MORE
FLEXIBLE**
through 2 components:
everything fits!

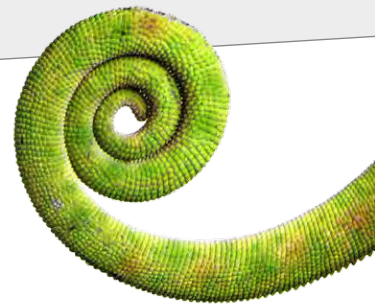

Device mount design



+ **Fix – immediate and fast**

- Pre-defined position of the gear trays
- Tailored rail lengths mean no reworking
- No tools or aids necessary



+ **Variable – flexible and individual**

- 100% free positioning of the gear trays within the mounting rail, with no collision spots
- Easy relocation of the gear trays (IP20)
- Various module lengths and cut-to-size blank covers (IP20/IP54) increase adaptation options.



FORMFACTOR

SRT TRUNKING

SINGLE-CONDUCTOR WIRING

- + Up to 11 individual wires for improved connectivity and emergency lighting
- + Fast assembly with push connections
- + Selection of cable cross-sections and tapping possibilities

100% VARIABLE

- + Free positioning of the gear trays
- + 3 module lengths
- + Gear trays with additional functions
- + Light colours and housing finishes

HIGHLY EFFICIENT LIGHTING TECHNOLOGIES

- + Suitable for every kind of application
- + Standard or power range
- + Very good glare control: $UGR \leq 19$



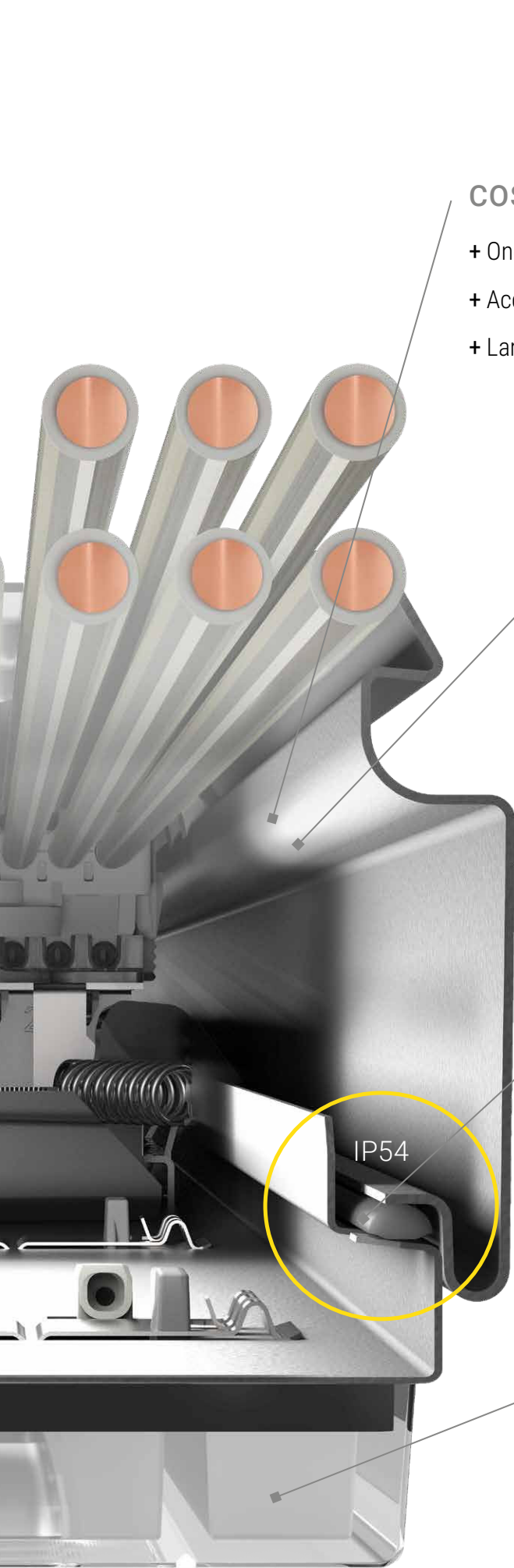

COST-EFFECTIVE

- + One mounting rail for all protection ratings
- + Accessories with click system
- + Large spacing (up to 4.5 m) between the rail fasteners

ELEGANT

- + Smooth design:
no visible screw connections
- + Gear tray locks design-integrated
- + Optically continuous trunkings

PROTECTION RATING

- + IP54 for exceptionally easy installation with no loss of light
- + Uniform appearance regardless of the protection class

IP54

MAINTENANCE-FRIENDLY

- + LED service life up to 100,000 h
- + Smooth surfaces
- + Remote maintenance via Regiolux Cloud
- + Exchangeable LED gear trays (eco-design)

MOUNTING RAIL

WIRING + SYSTEM LENGTHS

FLEXIBLE



Spacing between current taps: 767.5 mm
for gear trays /750, /1500, /2250

ECONOMICAL



INDIVIDUAL



Customer-specific positioning
of the current tap (BTO concept)

WIRING CONCEPT

Maximum flexibility or economic efficiency

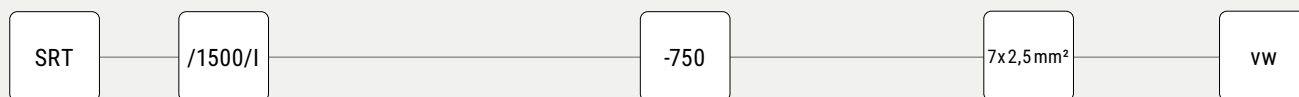

Mounting Rail Units	Length in mm
/0750	767.5
/1500/I	1535.0
/1500/II	3070
/1500/III	4605
/2250/I	2302.5
/2250/II	4605

Gear Tray Module	Number of Current Taps	
	-750	-2250
/0750	1	
/1500/I	2	
/1500/II	4	
/1500/III	6	
/2250/I	3	1
/2250/II	6	2

Wiring
7x2.5 mm ²
5x2.5 + 6x1.5 mm ²

Colour	
vw	traffic white RAL 9016
sg	silver grey/ white aluminium RAL 9006
sw	black RAL 9005

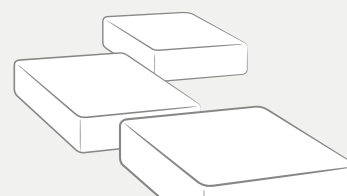

+ **Always at your side:** The increased number of current taps guarantees the right light in any place and creates more flexibility when function modules are used.

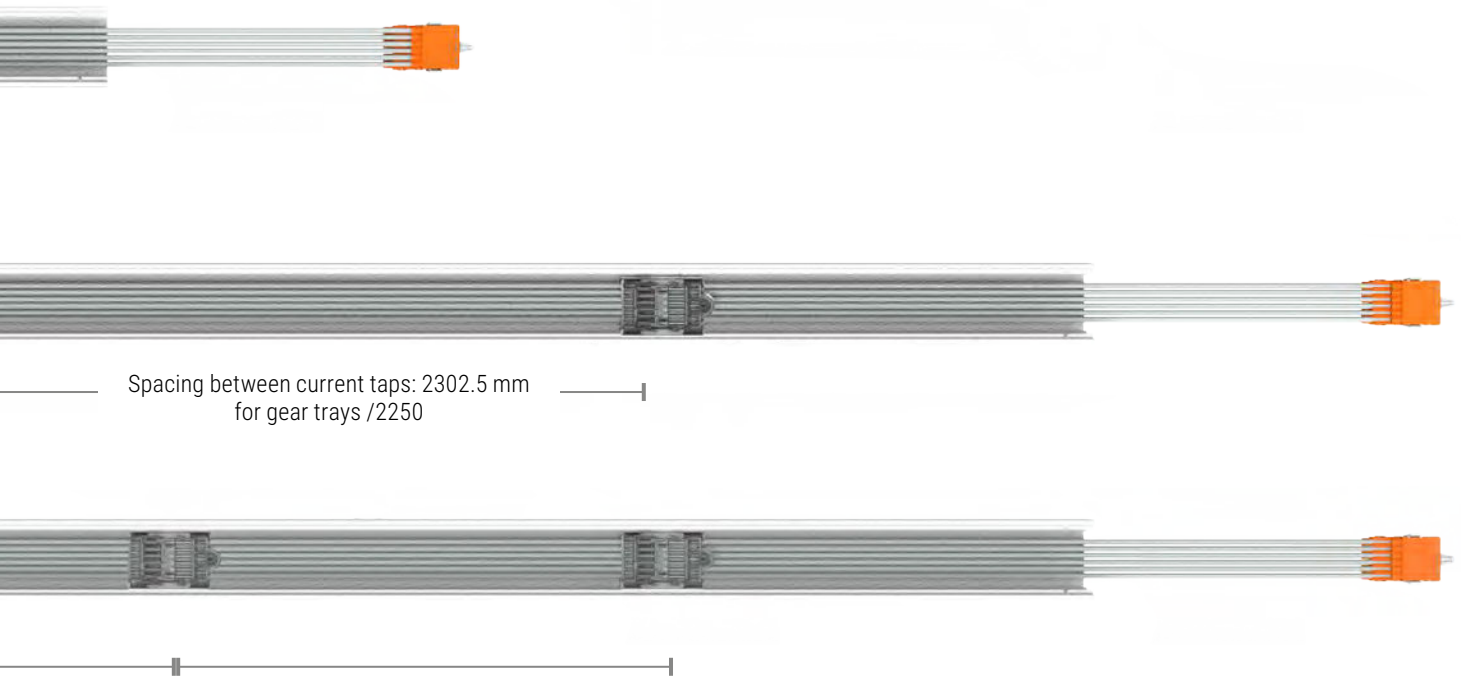

DESIGN

Single conductors for more possibilities and options

7-PIN

- 7 x 2.5 mm²
- 3 freely selectable phases
- 2 cables for DALI or emergency light

11-PIN

- 5 x 2.5 and 6 x 1.5 mm²
- 3 freely selectable phases
- 2 DALI control cables
- 2 independent emergency light supplies

BTO CONCEPT

- Cable cross-section
- DALI control cables
- Emergency light circuits
- Number of current taps
- Halogen-free wiring



MOUNTING RAIL

INFEEED – CONNECTION – OUTFEED

Beginning

Centre*

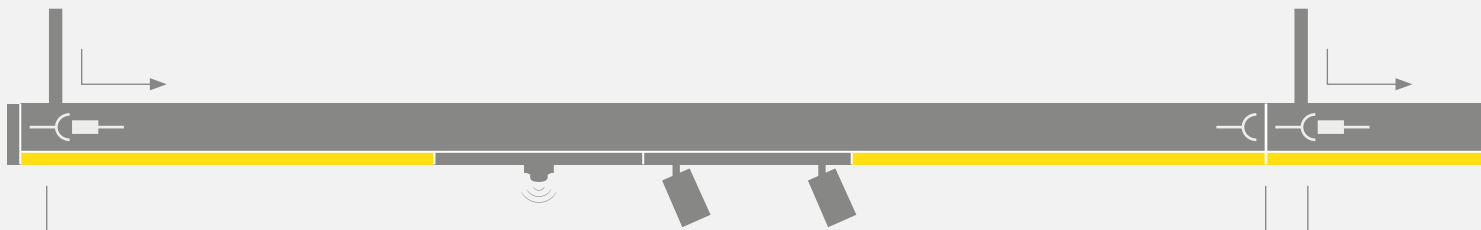

Beginning with infeed socket
incl. end cover for end of trunking



SRTA, 7- or 11-pin



End cover

■ Electrical connection via push system



Current tap
gear tray

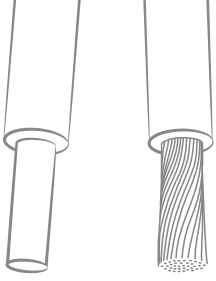

- + Infeed for rigid or flexible cable
- + Optically continuous trunking without interruption
- + Connection to the next trunking can be realised without additional wiring

End

Outfeed rail 1-length



New infeed with infeed socket

Outfeeds with SRT rail



SRTA, 7- or 11-pin

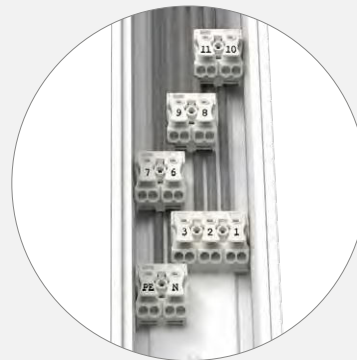

SRT-7A/1500/I
SRT-7A/2250/I
SRT-11A/1500/I
SRT-11A/2250/I

Bend up + latch in place – that's it!

click!
click!



MOUNTING RAIL

ACCESSORIES

SRT-AP*

Suspension profile



2 cable entries provided

SRT-ZA*

Central bracket



SRCT

Attachment to visible T-rail without drilling



SRD

Ceiling attachment, moveable



SRH

Chain suspension, adjustable without tools



Rail connector SRTV/SRTVL

Latching points maintain the position, cut-outs create space for feeders

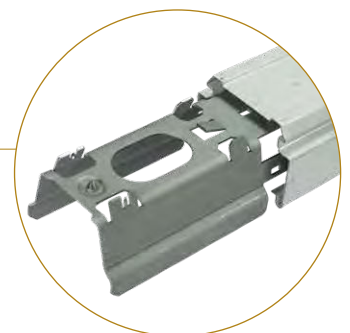

Attachment spacings: *up to 4500, 2500 or 3000 mm

INTUITIVE WITH CLICK SYSTEM

End faces

Tool-free installation with firm fixation

SRCS

Decorative rope suspension, adjustable without tools



SRTE IP20

incl. 2 pre-punched break-out openings



SRTES IP54

in 2-component design with 2 cable entries

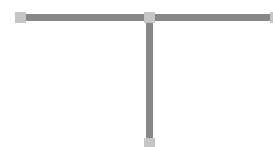
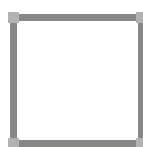

Connection points SRT-KL/SRT-KT

L and T connection points beautifully extend the linear lighting arrangements. Flexible connection cables simplify the installation.

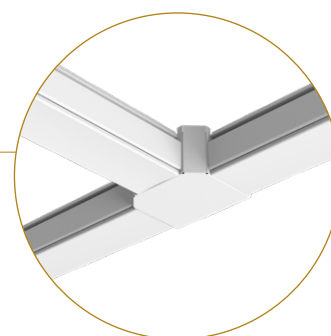
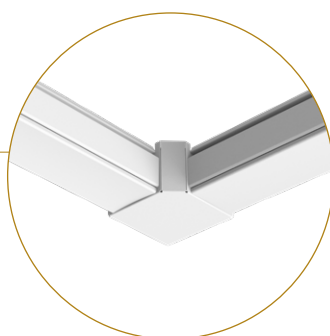

GEAR TRAY

MAIN FEATURES

Detailed solutions of elementary importance make a decisive contribution to the variability of the SRT trunking system. They allow us to respond precisely to requirements and wishes, and implement projects efficiently. The classic way of thinking in terms of systems

with module lengths has been dissolved in favour of precisely fitting positioning of the modules. This is especially true for IP54 applications. The plastic blank covers can also be shortened easily here.

Module lengths

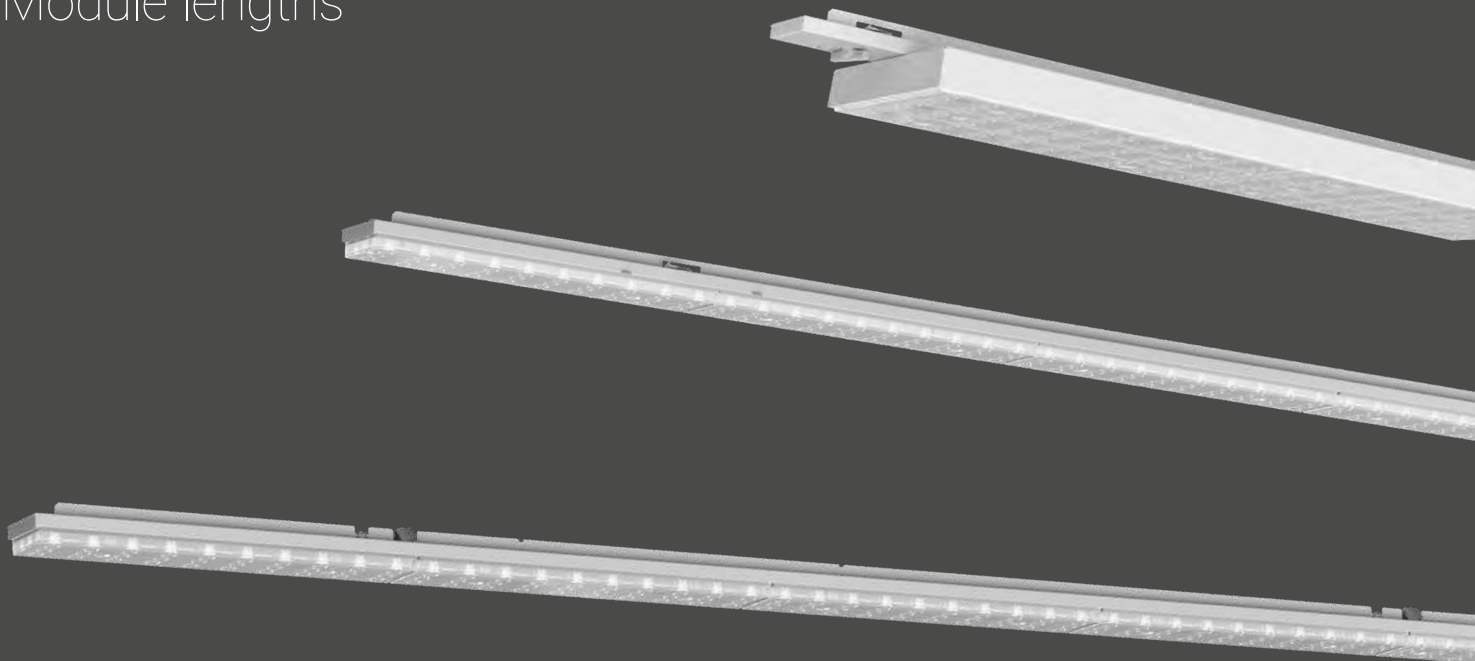

Positioning of the gear trays



fixed



variable

Protection ratings

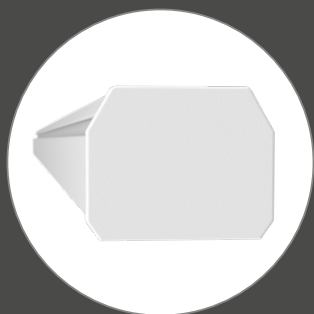

IP20

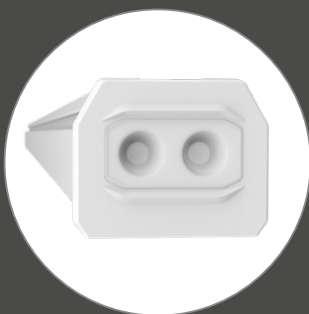

IP40/IP54



SRBKS, IP54
Blank cover can be shortened



Function module /750

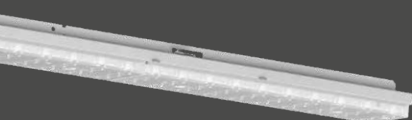

Module /1500

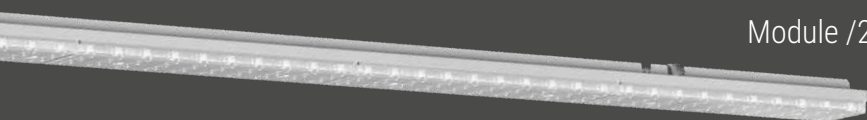

Module /2250

Housing colours

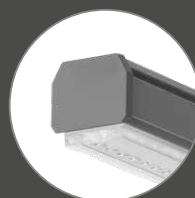

Light colours

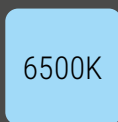
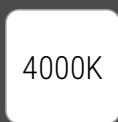
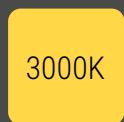

GEAR TRAY

LIGHTING TECHNOLOGIES



CENTRAL.LINE.OPTIC

SRGC ... module /1500 & 2250

- Even light distribution and homogeneity thanks to linear arrangement of individual lenses
- UGR<19, all-round glare control
- Luminous flux up to 22,000 lm, up to 195 lm/W
- Suitable for ambient temperatures from -20 to +50 °C
- Choice of 2 performance classes: standard or high-performance (HP)





INDIVIDUAL.LENS.OPTIC

SRGO ... module /1500 & 2250

- Maximum flexibility with 8 application-optimised optics
- UGR<19, all-round glare control
- SRGOTB: suitable for computer workstations (VDU)
- Standard or power range
- Luminous flux up to 19,000 lm, up to 186 lm/W
- Suitable for ambient temperatures from -20 to +45 °C
- Continuous design, uniform LED spacing



DIFFUSERS

SRG ... module /1500

- Frosted, prismatic or opal diffusers
- Direct/indirect light beam distribution
- Homogeneous illumination
- Luminous flux up to 11,000 lm, up to 176 lm/W
- Suitable for ambient temperatures from 0 to +45 °C



CENTRAL.LINE.OPTIC



All lined up!

Product highlights

- + **Economical:**
Fewer device mounts thanks to larger lumen packages, with peak values of 44,000 lm over 4.5 m
- + **Perfected optics:**
 - wide beam: optimum illumination at a low height
 - narrow/wide beam: the all-rounder
 - narrow beam: a good choice for logistics projects and rack aisles.
- + **Efficient / bright light:** Available in 2 efficiency classes
- + **Sturdy:**
Suitable for rough ambient conditions
IP54, also variable

Design-integrated features

- + Optically continuous light line
- + Lateral edge brightening
- + Transparent IP54 seal
- + Easy to clean surface
- + No visible screws
- + Theft and disassembly safeguard

	Standard	High-performance
Rated service life (max. tq)	L80 B10 50,000 h L80 B50 70,000 h L80 B50 100,000 h	L80 B10 70,000 h L80 B50 100,000 h
Ambient temperature (ta) IP20, IP54	from -20 to +35 °C	from -20 to +50 °C
Lumen	4,000–21,000 lm	5,000– 22,000 lm
Efficiency	163–193 lm/W	173– 195 lm/W

Lighting technology

TIR lens design

The Central.Line.Optic uses the principle of total internal reflection (TIR) for optimum light control efficiency.



Individual lens, 1-row made of PMMA, for 2 LED light points, even light distribution, homogeneous illumination, all-round glare control

NEW

SRGC Central.Line.Optic



Optics

... CB

wide



4,000–22,000 lm

UGR ≤ 22

Installation height:
3–5 m



... CTB

narrow/wide



4,000–22,000 lm

UGR ≤ 19

Installation height:
3–10 m

... CT

narrow



4,000–22,000 lm

UGR ≤ 22

Installation height:
6–16 m



Housing colours



RAL 9016



RAL 9006



RAL 9005



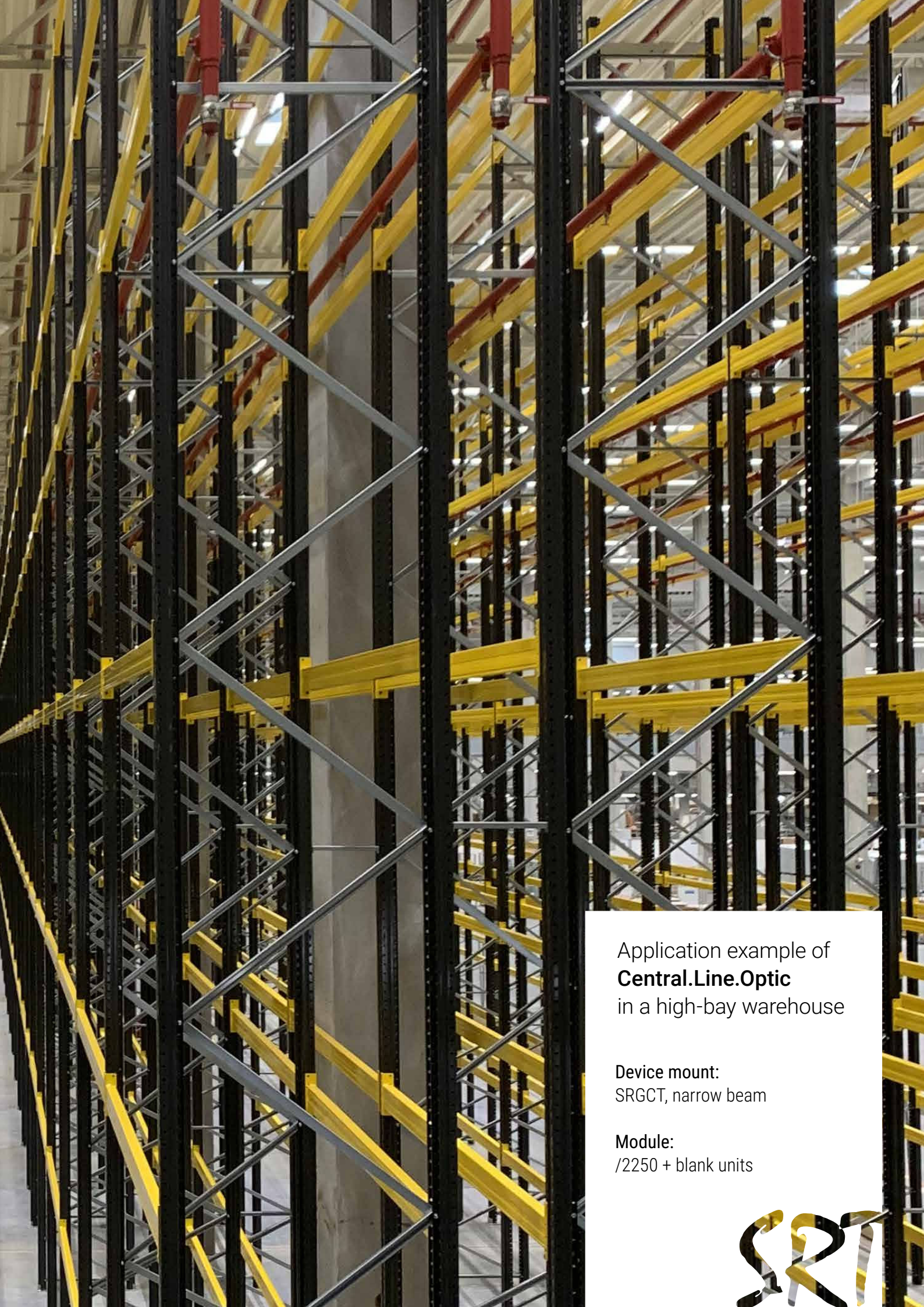

Application example of
Central.Line.Optic
in a high-bay warehouse

Device mount:
SRGCT, narrow beam

Module:
/2250 + blank units



DIFFUSERS

More homogeneous
than ever before!



Product highlights

- + **Diffuser:** Even light diffusion at the highest level
- + **Unusual:** Calculated prismatic design in frosted look *narrow/wide beam* – ideal for manual warehouses (... LP)
- + **Pleasant:** Indirect light component for brightened ceilings and open room atmosphere (... LP, LK)
- + **Functional:** Tunable white
Human Centric Lighting (SRGV)
Adjustable luminous fluxes with multi-lumen

Design-integrated features:

- + Homogeneous appearance
- + No visible seals for IP40/IP54
- + Frosted trunking optic with no visible light points
- + Integrated emergency light function

SRGLP lighting technology

Inner prism system combined with a slightly frosted diffuser, diffuser made of PMMA with focussed scattering nano-particles, even light distribution with trunking character, homogeneous illumination, optimised for narrow/wide beam light distribution

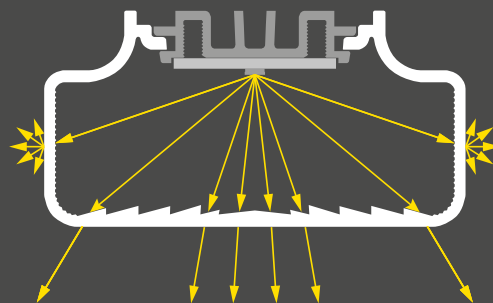

NEW



SRGLK
IP20

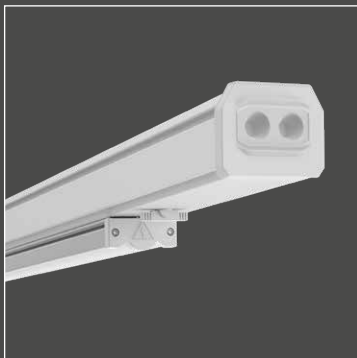

SRG(V)
IP20
IP40
IP54



SRGLP
Diffuser

Optics

SRG(V)

frosted

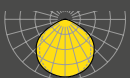

4,200–8,100 lm

UGR ≤ 22

Installation height:
2.5–5 m

... LP

prismatic

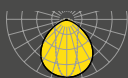

5,000–11,000 lm

UGR ≤ 22

Installation height:
2.5–5 m

... LK

opal



5,000–10,000 lm

UGR ≤ 25

Installation height:
2.5–5 m

Housing colours



RAL 9016



RAL 9006



RAL 9005





7
146

145



Application example
Diffuser
in the small parts
warehouse

Device mount:
SRGLP,
diffuse narrow/wide beam

Module:
/1500 + blank units

SRT

INDIVIDUAL.LENS.OPTIC

Greatest possible variety!



Product highlights

- + **Harmonious:** Even light point distribution thanks to 3-row arrangement of individual lenses
- + **Efficient / bright light:** Available in 2 efficiency classes up to 186 lm/W
- + **Varied:** 8 application-optimised optics for a wide range of different tasks
 - extremely wide beam:* optimum illumination at a low height, even in the top rows of racks
 - wide beam:* optimum illumination at a low height
 - narrow/wide beam:* area illumination at higher installation heights, up to 5,500 lm VDU-compatible, glare control, $UGR \leq 19$ (... OTB)
 - narrow beam:* logistics projects and rack aisles
 - extremely narrow beam:* high-bay racks in logistics projects
 - asymmetrical beam:* ideal for panel illumination, galleries, goods presentations, loading ramps
 - double asymmetrical beam:* perfect for racks and aisles
 - diffuse distribution:* homogeneous area illumination
- + **Pleasant:** Indirect light share for brightened ceilings and open room atmosphere (... OG)
- + **Economical:** Construction site packaging as standard, cost-optimised systems with long module /2250

Optics

... OXB	... OB	... OTB	... OT	... OH
extremely wide	wide	narrow/wide	narrow	extremely narrow
4,000–12,000 lm	4,000–19,000 lm	4,000–19,000 lm	4,000–19,000 lm	8,000–12,000 lm
$UGR \leq 22$	$UGR \leq 22$	$UGR \leq 19$	$UGR \leq 22$	$UGR \leq 16$
Installation height: 2.5–5 m	Installation height: 3–5 m	Installation height: 3–10 m	Installation height: 6–16 m	Installation height: > 10 m

NEW

SRGO Individual.Lens.Optic

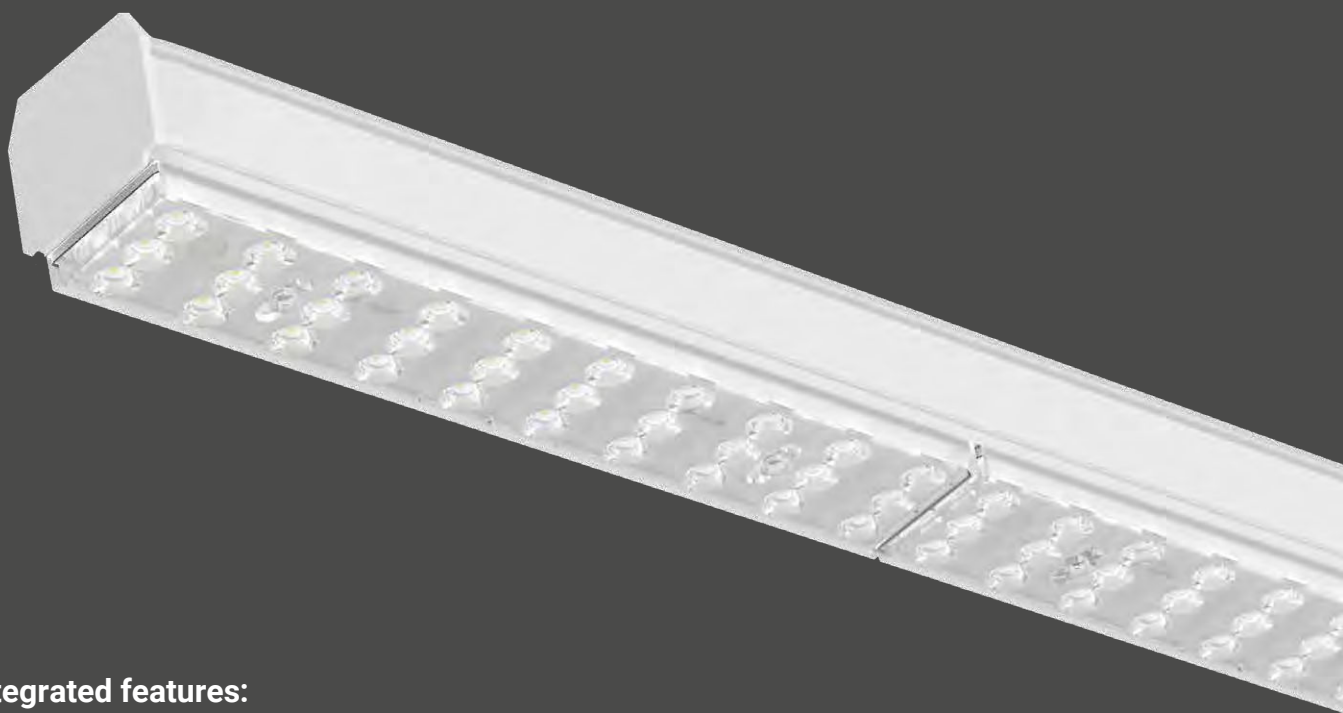

Design-integrated features:

- + Transparent IP54 seal
- + Continuous appearance
- + Easy to clean surface
- + Theft and disassembly safeguard

... OA

asymmetrical



4,000–12,000 lm

UGR ≤ 22

Installation height:
3–4 m

... ODA

double asymmetrical



4,000–12,000 lm

UGR ≤ 19

Installation height:
3–4 m

... OG

diffuse



4,000–12,000 lm

UGR ≤ 25m

Installation height:
3–5 m

Housing colours



RAL 9016

RAL 9006

RAL 9005





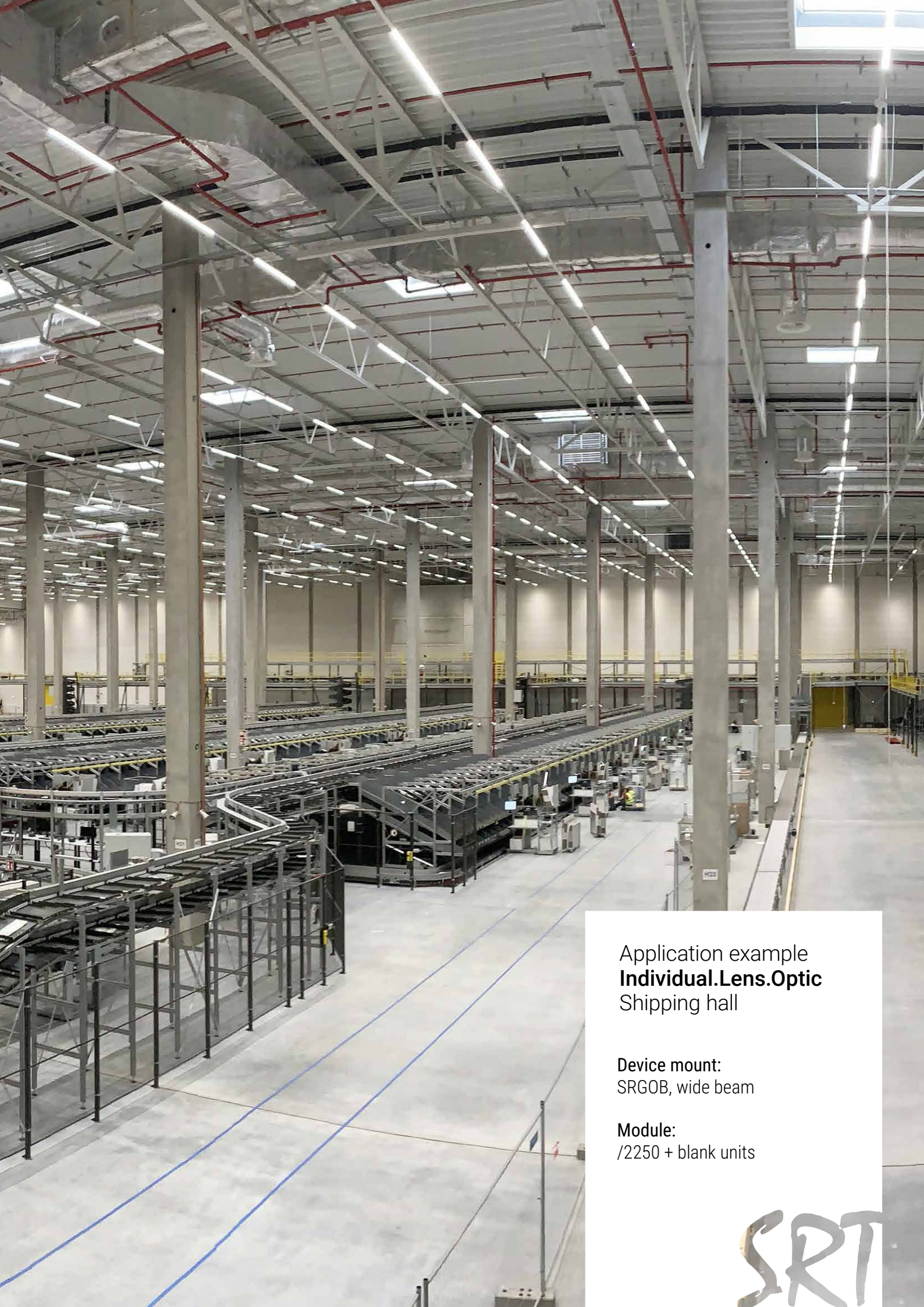

Application example
Individual.Lens.Optic
Shipping hall

















Device mount:
SRGOB, wide beam

Module:
/2250 + blank units

SRT

LIGHTING TECHNOLOGY

OVERVIEW

	LENS OPTICS				
Code	... XB	... B	... TB	... T	... H
Light control	extremely wide	wide	narrow/wide	narrow	extremely narrow
Light distribution					
Installation height	2.5–5 m	3–5 m	3–12 m	6–12 m	>10 m
Central.Line.Optic		 SRGCB	 SRGCTB	 SRGCT	
Individual.Lens.Optic	 SRGOXB	 SRGOB	 SRGOTB 	 SRGOT	 SRGOH
Diffuser					
Application					

























Central.Line.Optic

Individual.Lens.Optic

Diffuser

Prismatic diffuser

SRF diffuser

	LENS OPTICS			DIFFUSER OPTICS			
	... A	... DA	... G	... LK	... LP	SRG	
	asymmetrical	double asymmetrical	frosted	opal	prismatic	frosted	
							
	3–4 m	3–4 m	3–5 m	2.5–5 m			
	 SRGOA	 SRGODA	 SRGOG				
				 SRGLK	 SRGLP	 SRG	
	   		   			 	

 For further gear trays see *function modules*

LIGHTQUALITY

Our perception is largely determined by light and colour. These are inseparable partners. Light and colour, together with the perception of form, become an overall picture. They are an essential specification in the planning of lighting solutions.





Choosing the right colour temperatures

Light colours exercise influence. The psychological effect of light colours is undisputed. We take this into account when developing lighting concepts and adapt them to the various intended effects and tasks. With tunable white technology or the simulation of the natural progression of daylight by Human Centric Lighting (HCL), dynamics come into play. Our SRT system can do all this, because flexibility is also required here.

Standard	830:	CRI 80 3,000 K
	840:	CRI 80 4,000 K
	865:	CRI 80 6,500 K
	TW:	CRI 80 3,000–6,000 K

Build-to-Order	850:	CRI 80 5,000 K
	930:	CRI 90 3,000 K
	940:	CRI 90 4,000 K
	950:	CRI 90 5,000 K
	965:	CRI 90 6,500 K
	:	

Colours in the type designation

You will find codes for the LED colour values in the SRT type designation of the device mounts, the Scrabble. The first digit stands for the colour rendering index (CRI/Ra value), the others for the colour temperature in Kelvin.

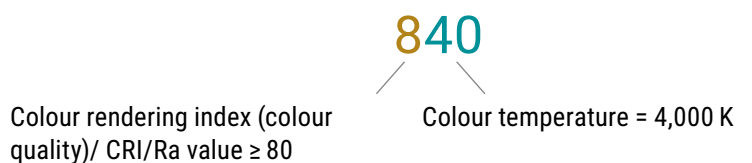

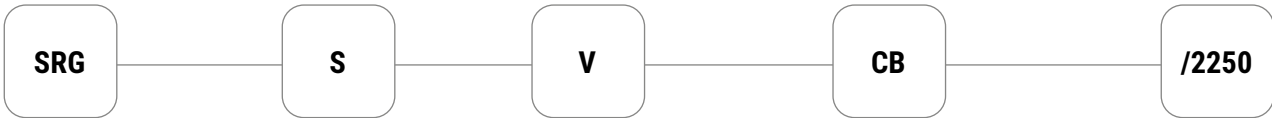

Gear Tray

SRG for SRT light run

Protection rating

without	IP20
S	IP54

Positioning in the light run

with-out	fixed
V	variable

Optic

Central.Line.Optic

CB	wide beam
CTB	narrow/wide beam
CT	narrow beam

Individual.Lens.Optic

OXB	extremely wide beam
OB	wide beam
OTB	narrow/wide beam BAP
OT	narrow beam
OH	extremely narrow beam
ODA	double asymmetrical
OA	asymmetrical beam
OG	frosted direct/indirect distribution

Diffuser

SRG	frosted, direct lighting
LK	diffuse direct/indirect distribution
LP	diffuse, inner prism; direct/indirect distribution, narrow/wide beam

Module length

/0750	767.5 mm
/1500	1531 mm
/2250	2299 mm

CHOOSE YOUR LIGHT MODULE HERE.

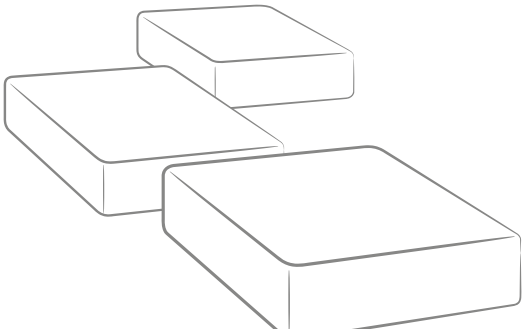

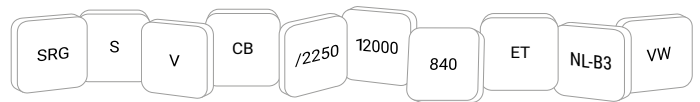

GUIDE

GEAR TRAY

The SRT type designations are composed of a logical sequence of abbreviations and value specifications. These are always in the same position and can thus be read like Scrabble and are self-explanatory.



Lumen package			
Central.Line.Optic			
Standard		High Performance	
/1500	/2250	/1500	/2250
4000	7000	5000	7000
6000	9000	6000	10000
8000	13000	9000	13000
8200-4600	16000	11000	17000
11000	21000	15000	22000
14000			

Individual.Lens.Optic	
/1500	/2250**
4000	7000 BAP
5500 BAP	10000
6000	14000
8000	19000

8200-4600	
9000	
10000	
12000	** Optic: OB, OTB and OT

Diffuser		
SRG /1500	LK /1500	LP /1500
4200	5000	5000
7000	6000	6000
8100-4800	7500	7500
	8300-4600	8900-4800
	10000	11000

Light colour	
830	3000K, CRI 80
840	4000K, CRI 80
850*	5000K, CRI 80
865	6500K, CRI 80
930*	3000K, CRI 90
940*	4000K, CRI 90
950*	5000K, CRI 90
965*	6500K, CRI 90

Type of circuit	
ET	electronic driver, switchable
ETM	multi-lumen
DALI	dimmmable
DALI CLO	Constant Lumen Output
DALI DT8	Tunable white

Emergency lighting	
NL-B3	Single 3h battery
NL-B3 DT1*	Single 3h battery (centrally monitored)
NL-ZB*	Central battery (centrally monitored)

Housing colour	
vw	traffic white RAL 9016
sg	silver grey/white aluminium RAL 9006
sw	black RAL 9005

*Build-to-Order

Our concept for your customised project solutions: Build-to-Order (BTO)





GEAR **TRAYS**

FUNCTION MODULES

SAFETY LUMINAIRE	<i>SAFE</i>	<i>P. 56</i>
SPOTLIGHT	<i>SPOTTY-MAXI</i>	<i>P. 58</i>
AREA LUMINAIRE	<i>ZATTA</i>	<i>P. 60</i>
TRACK	<i>SRGD</i>	<i>P. 61</i>
LIGHT MANAGEMENT	<i>NETLIFE</i>	<i>P. 62</i>

EMERGENCY LIGHT MODULE SAFE



Product highlights

- + Plug & play gear tray incl. safety luminaire
- + Simple, low-key design, also in IP54
- + LED with area or escape route lens, can be turned through 90° for adaptation to aisles
- + Integrated theft and dismantling protection
- + With a choice of single 3 h battery (NL-B3) or for central battery systems (NL-ZB)

Luminaire spacing (m)

Optic	Area 1 lx total area		Area acc. to standard		Escape route or corridor	
	L-L	L-W	L-L	L-W	L-L	L-W
3,0	6,1	3,4	8,7	4,1	11,0	2,5
5,0	7,7	1,8	12,6	5,0	15,3	2,0
6,0			13,3	3,1		
8,0	9,2	2,0	12,0	1,0	10,5	3,5
11,0	10,7	3,6	12,0	0,8	7,0	0,8

MH= Installation height, L-L= Distance luminaire to luminaire
L-W= Distance luminaire to wall or entrance/exit corridor

Lighting technology:

- + Symmetrical lens for areas – extremely wide beam (XB)
- + Double asymmetrical lens (DA) e.g. rack aisles, for escape routes





Emergency lighting in the SRT trunking system

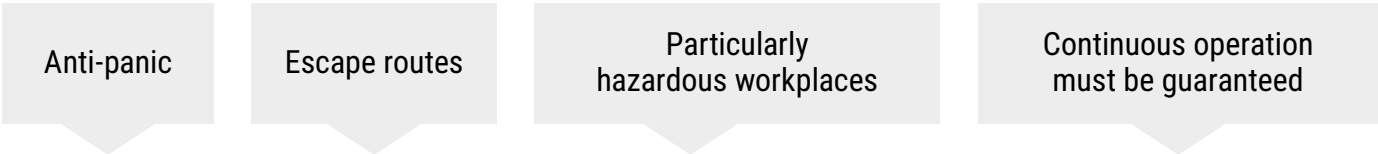

Single 3 h battery (optional central monitoring)
Central battery (central monitoring)

Integrated in the gear tray

Homogeneous appearance with all optics.

Module/1500, module /2250
SRG + lighting technology



Emergency light module safe

for emergency exits and escape routes

SRGV/750 safe



SPOTLIGHT SPOTTY-MAXI



Product highlights

- + Gear tray combined with 2 spotty-maxi spotlights
- + Ideal as accent and display lighting in shops and retail areas
- + Excellent light quality and a colour rendering index of up to Ra > 90
- + High-efficiency, interchangeable segment reflector of MIRO SILVER, beam angle 30° (standard), 20° or 60° as accessory
- + Gear tray module /1500 with Individual.Lens.Optic and 2 spotty-maxi spotlights

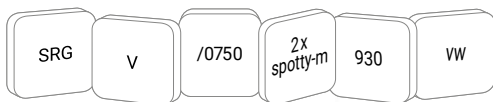

Trunking
+ spotlight

Get the best
of both worlds

A vibrant display of fresh vegetables in wicker baskets. The foreground features a basket filled with bright red tomatoes and green cucumbers. Behind it, another basket is overflowing with more red tomatoes. In the background, there are baskets containing yellow and red bell peppers, and a large green leafy vegetable, possibly a cabbage or lettuce. The scene is lit with warm, golden light, creating a rich and appetizing atmosphere. A semi-transparent white box with text is overlaid on the upper left portion of the image.

The right light for
every product
category

AREA LUMINAIRE ZATTA

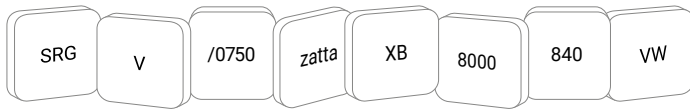

Product highlights

- + Gear tray with design-oriented zatta area luminaire is an effective highlight
- + Attractive shop and retail applications
- + Lighting technology with Individual.Lens.Optic
- + Even light distribution, homogeneous illumination, all-round glare control
- + 3 housing colours for customised shop design

BTO

- + Choice of 8 lighting technologies
- + *zatta* can be turned through 90°, follows changes of use in retail

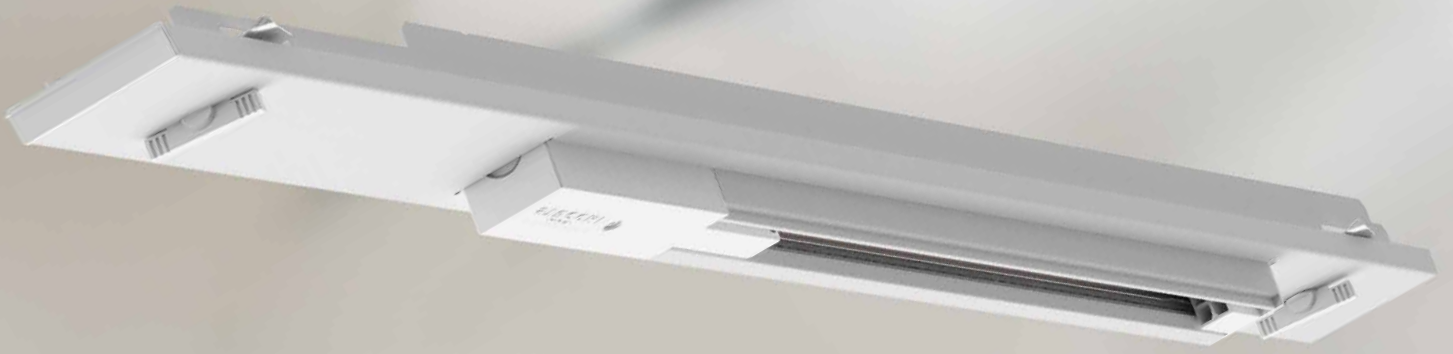

TRACK SRGD

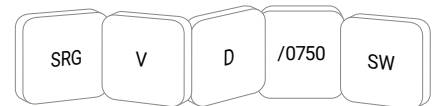

Product highlights

- + Gear tray with integrated universal 3-phase track incl. DALI
- + For use with further spotlights for spot highlighting
- + Can be used with all universal track adapters
- + Ideal for combining accent and general lighting
- + 100% variable positioning

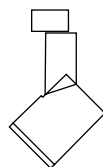

emphara

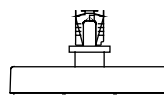

zatta

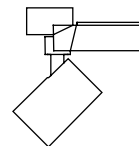

spotty

NETLIFE

SRT LIGHT MANAGEMENT

NETLIFE – capitalise on convenience and cut costs

- + 1 concept, 3 solutions – free choice of level
- + Completely integrated in the SRT light run system
- + For flexible positioning in IP20 and IP54
- + Scalable solution from simple to complete, from one area to world-wide covering several locations
- + Open for your wishes from planning through to commissioning





NETLIFE

1 CONCEPT – 3 SYSTEM SOLUTIONS

Fields of application

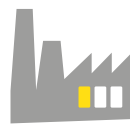

One area

- + Quick and easy planning and installation
- + Stand-alone system
- + Wired
- + Motion and daylight control



Areas

- + Quick and easy planning and installation
- + Hybrid system: wireless/wired
- + Motion and daylight control
- + Additional features

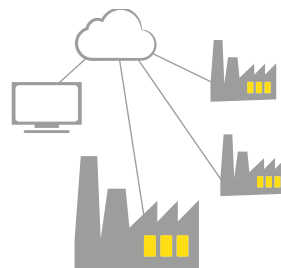





One or more buildings,
Cloud solution

- + Higher-level building control (BMS)
- + Wired
- + Motion and daylight control
- + Event-driven actions and links



The *netlife* concept contains three solutions with different expansion levels for light management in the SRT light run system. At Regiolux, the Advanced Services department is your contact for conceptional considerations, design, project planning and commissioning of light control systems. Project solutions with automatic position determination can be implemented with the BTO concept.

Advanced Services:
+49 (0) 95 25 89-260

<i>netlife</i> system solution:	EASY	FLEX	PRO
	One area	Areas	One building, several locations
Control	SRT light run		Higher-level Building Management System (BMS)
Commissioning	Remote control	Casambi app	System control software
Dimming 	●	●	●
Movement detection	●	●	●
Daylight-dependent control	●	●	●
Orientation light, corridor function	●	●	●
Guided Light	●	●	●
Scenes and groups		●	●
HCL		●	●
Timer, calendar		●	●
Network integration		●	●
Predictive maintenance – remote maintenance and diagnosis			●
Monitoring – collect, evaluate and monitor system data			●
Tracking – know where what is			BTO
Indoor navigation – find your way around			BTO
Heat mapping			BTO
Convenience			

SRGNETLIFE

SENSOR MODULES



easy21

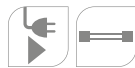

- Plug & play function module
- Stand-alone concept without higher-level control
- Up to 30 DALI devices can be controlled



flex33



- Wireless dimming and control via Bluetooth and app up to 12 metres installation height
- Several wireless sensors, even external ones, can be controlled via one module
- Predestined for refurbishment solutions
- No DALI bus wiring necessary

Building Management:



pro14



pro14 + Regiolux-Cloud

- Gear tray for connection to building management systems e.g. from Wago or RX professional: LC
- Cloud application permits central data storage; control and coordination of processes
- Event-driven actions and links from DALI2
- Uses existing DALI rail wiring
- Simple and fast adaptation of room use



pro47



KNX solution: pro47 + KNX-DALI gateway

- Gear tray for connection to KNX systems via additional DALI gateway
- No installation work in the KNX system
- Uses existing DALI rail wiring
- No KNX bus wiring necessary

See online catalogue for further accessories such as switches, couplers, external sensors

FIELDS OF APPLICATION

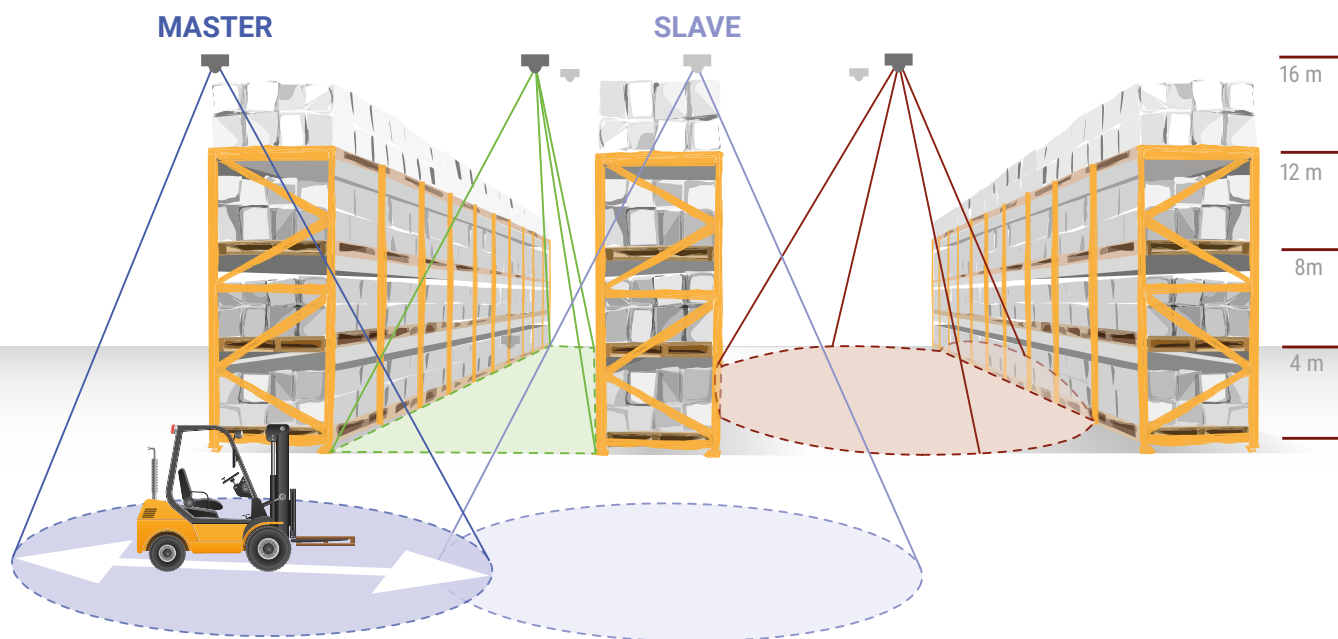

netlife function module	Field of application		Installation height	Protection rating				Control- lers
	(High-)bay warehouses and aisles	Zones and areas		IP20: SRGV		IP54: SRGSV		
Expansion level	Detection range			Master	Slave	Master	Slave	max.
			5-16 m	easy07	easy20	easy07	easy20	50
			4-14 m	easy21	easy22	easy21	easy22	30
			2-10 m	easy15	easy19	easy15	easy19	50
			4-14 m	easy23	easy24	easy23	easy24	30
			5-12 m	flex35	flex33	flex39	flex37	32
			5-14 m	flex36	flex34	flex40	flex38	32
	DALI2 RX		5-16 m	pro08		pro08		
			5-16 m	pro09		pro09		
			2-10 m	pro13		pro13		
			2-5 m	pro14		pro14		
	KNX		5-16 m	pro47		pro47		

STRENGTHS

QUALITY FEATURES



Guarantee: 5 years, 8 years on request



Service life permanently reliable
L80 B10 50.000 h–L80 B50 100.000 h



Ambient temperatures from
-20 to 50 °C



Extremely efficient operation
up to 195 lm/W



Suitable for dry indoor spaces



Protection against penetration by solid objects
with a diameter > 1 mm



Dust- and splashwater-proof; standard even
with variable device mounts



Suitable for premises with fire hazards



Excellent glare control and visual comfort



Suitable for computer workstations



Plug & play: simple, fast installation with
immediate use



Electronic driver



Multi-lumen driver with adjustable luminous
flux allows fast adaptation following changes
in room use



Electronic DALI driver, dimmable



Constant Lumen Output – for constant light
output over the entire service life, exact
dimensioning of the illuminance saves energy



DALI, tunable white



HCL (Human Centric Lighting):
Simulation of natural progression of daylight,
biologically effective light



Coming soon:
European safety quality mark
for luminaires



IoT-ready; supports standards for connected lighting
technology

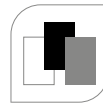

3 system colours to choose from



Emergency light in all device mounts for
greater safety in the building



BIM-ready; Autodesk-Revit data
in the online catalogue



Sensor system with netlife light management



Suitable for use by certified companies in the food
industry

TRUNKING

CONFIGURATION

Example: 1 x 10-length light run

Light run length: 15.35 m

SRT/1500/III				SRT/1500/III			SRT/1500/III			SRT-11A /1500/I	
SRGCB/1500	SRGCB	spotty	netlife	SRGCB	SRGCB	SRGCB	SRGCB	spotty	safe	SRGCB	SRGCB

3	ST	Mounting rail, 3-length	SRT/1500/III-750 5x2.5+6x1.5 mm ² vw
1	ST	Mounting rail incl. outfeed, 1-length	SRT-11A/1500/I-750 5x2.5+6x1.5 mm ² vw
1	ST	End face (pair)	SRTE
3	ST	Rail connector	SRTV
8	ST	Gear tray	SRGCB/1500 LED 8000 ET 840 vw
2	ST	Gear tray, spotlight function module	SRGV/0750 2 x spotty-M 30° 840 ET vw
1	ST	Gear tray, light management function module	SRGV/0750 netlife flex35 vw
1	ST	Gear tray, safety luminaire function module	SRGV/0750 safe XB NL-ZB vw
7	ST	Chain suspension	SRH
1	ST	Infeed adaptor	SRTA-11E

Online light run configurator
coming soon!

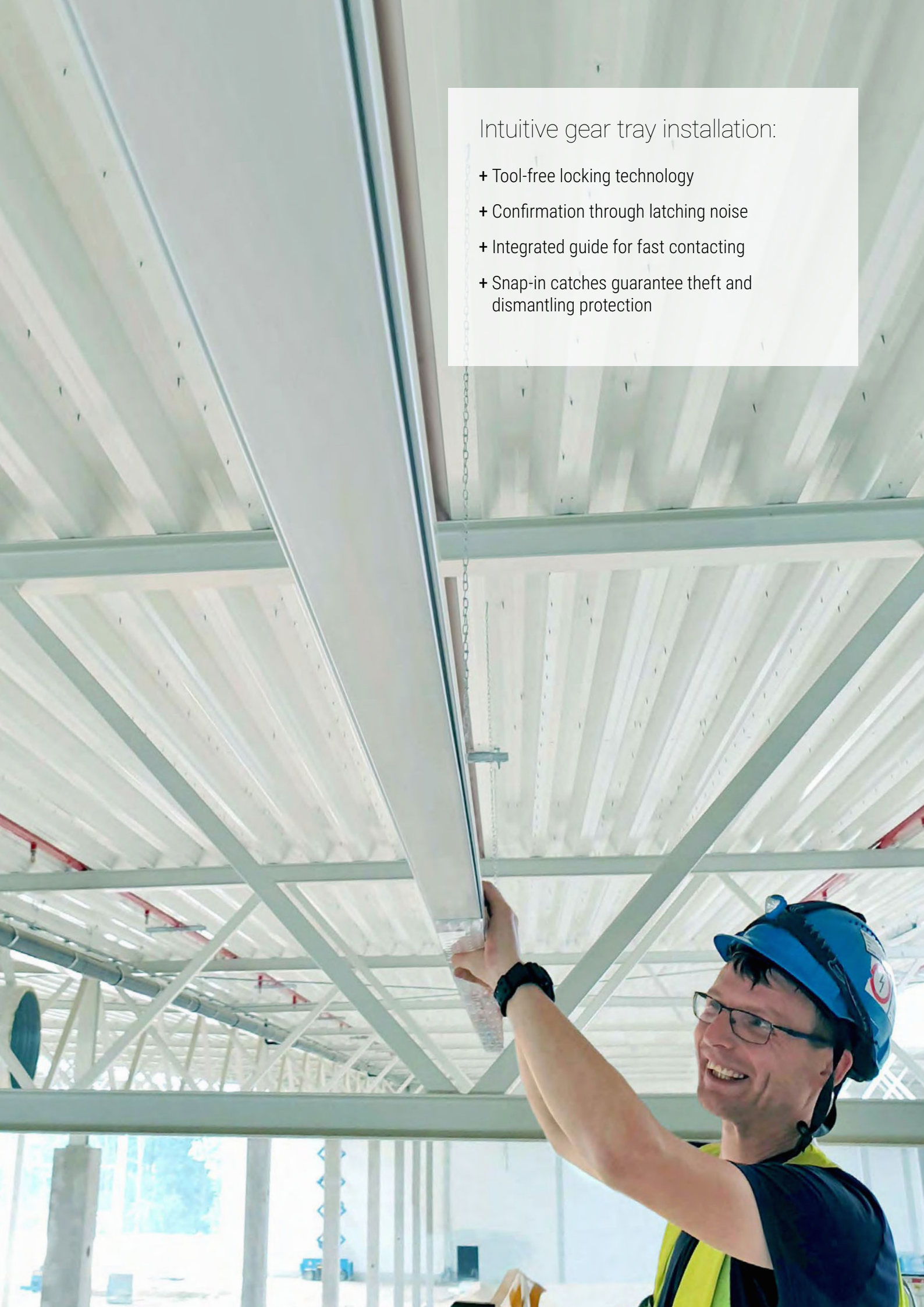

Intuitive gear tray installation:

- + Tool-free locking technology
- + Confirmation through latching noise
- + Integrated guide for fast contacting
- + Snap-in catches guarantee theft and dismantling protection



LOGISTICS PROJECT

LIGHT PLANNING

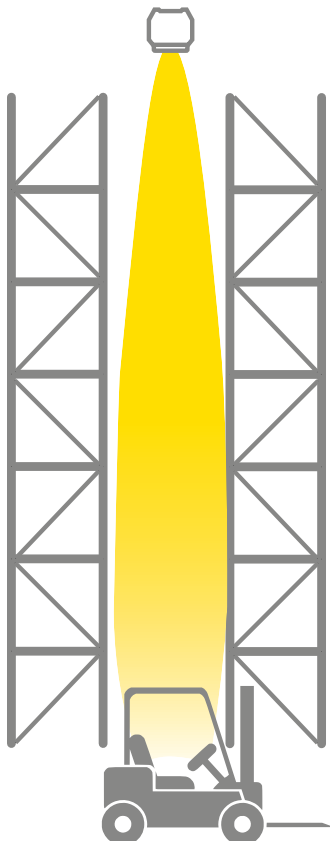

PLANNING EXAMPLE

Logistics hall with high-bay warehouse

Task

Dimensions (L/W)	120 x 2.50 m
Installation height	12 m
Illuminance	>150 lux, work plane floor

SRT solution

Luminaire type	SRGVCT/2250 LED 21,000 lm, 840, DALI
Lighting technology	Central.Line.Optic, narrow beam
Number of luminaires	1 light run with 13 luminaires and 12 blank units



INDUSTRY PROJECT

LIGHT PLANNING



PLANNING EXAMPLE

Industrial hall

Task

Dimensions (L/W)	50 x 30 m
Installation height	8 m
Illuminance	> 300 lux, work plane 0.75 m

SRT solution

Luminaire type	SRGSVCTB /1500 LED 10000 840
Lighting technology	Central.Line.Optic narrow/wide beam
Number of luminaires	5 light runs with 13 luminaires each and 12 blank units

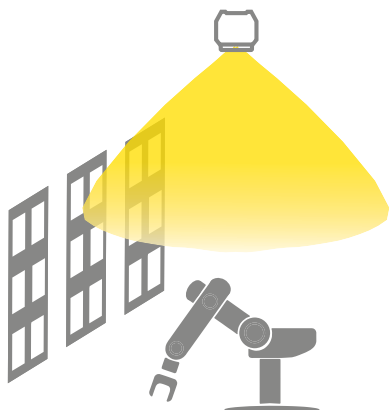



RETAIL PROJECT

LIGHT PLANNING



PLANNING EXAMPLE

Retail

Task

Dimensions (L/W)	20 x 2 m
Installation height	4 m
Illuminance	> 300 lux, work plane 0.75 m

SRT solution

Luminaire type	SRGV/0750 zatta B 8000 840
Lighting technology	Individual.Lens.Optic, wide beam
Number of luminaires	5 units <i>option for accent lighting:</i> Function module with <i>spotty-m</i> spotlight





EDUCATION PROJECT

LIGHT PLANNING



PLANNING EXAMPLE

Classroom

Task

Dimensions (L/W)	9.60 x 7.20 m
Installation height	3 m
Illuminance	> 500 lux, work plane 0.75 m

SRT solution

Luminaire type	SRGVOB /1500 LED 4000 840 + SRGOA /1500 LED 6000 8400
Lighting technology	Individual.Lens.Optic, wide beam or asymmetrical beam
Number of luminaires	2 light runs with 4 luminaires each, wide beam, and 3 blank units; 1 light run with 3 luminaires, wide beam, and 2 blank units; 1 light run with 2 luminaires, asymmetrical beam

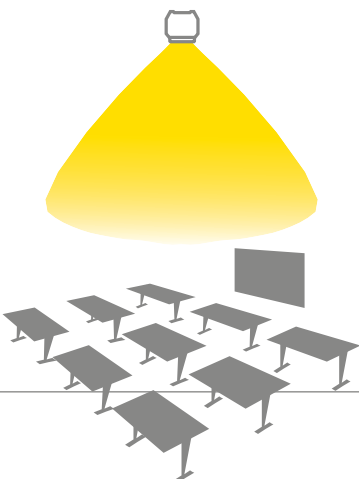



OFFICE PROJECT

LIGHT PLANNING



PLANNING EXAMPLE

Office

Task

Dimensions (L/W)	12 x 6 m
Installation height	3 m
Illuminance	> 500 lux, work plane 0.75 m

SRT solution

Luminaire type	SRGOTB /1500 LED 4000 840
Lighting technology	Individual.Lens.Optic, narrow/wide beam
Number of luminaires	2 light runs with 6 luminaires each

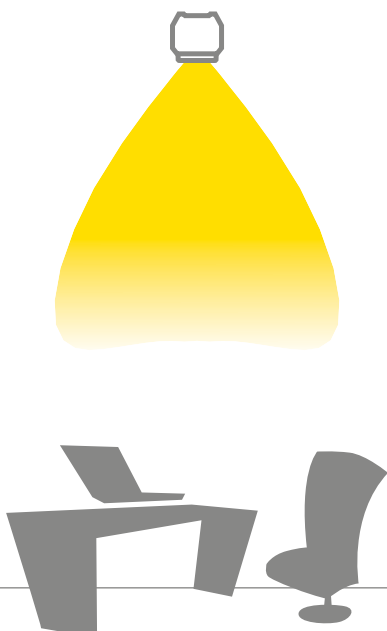

PACKAGING CONCEPT

The SRT gear trays are available in a choice of two packaging sizes. We have turned the 1 x 1 individual packaging into a 3 x 3. The choice is yours.

With the tailor-made bulk units you save packaging material. As well as saving time, your waste disposal costs are reduced too. And it benefits the environment.



3x3

Safe and simple access: 3x3 device mounts in bulk packaging are quickly on hand.

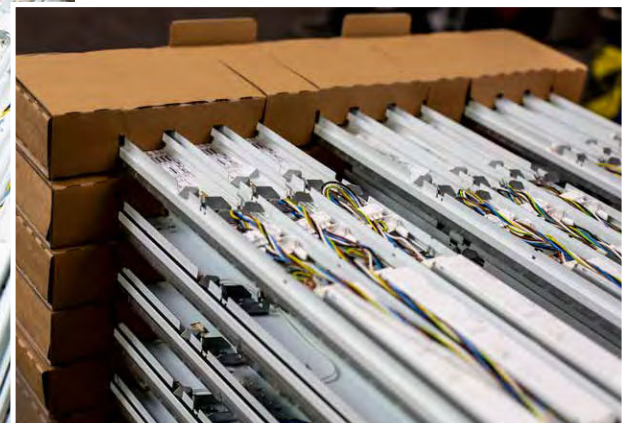



ALL-ROUND **SERVICE**

SERVICES

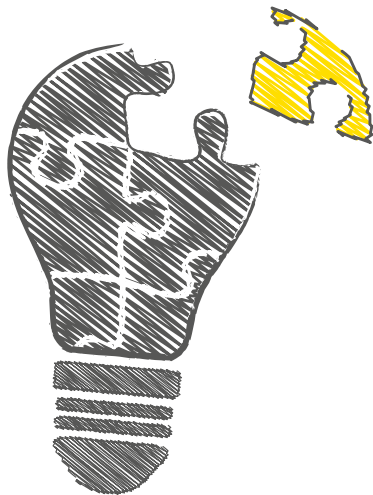

We have always focused on bespoke customer solutions, because every project solution is different and has its own challenges. Our all-round services include

- + Mounting/Installation
- + Financing
- + Leasing
- + Funding

Let's talk about it!



Would you like to find out more?

Give us a call:

+49 (0) 95 25 89-220



REGIOLUX

Regiolux GmbH
Hellinger Straße 3
D 97486 Königsberg
T +49 9525 89 0
info@regiolux.de
www.regiolux.de

PDF 



Regiolux @ Social Media

